



SPECIFICATIONS FOR CITY ORDINARY BUS BODIES (TATA-244"WB-12M) -2018

1.0 GENERAL DESIGN:

The general design shall be a streamlined body with two passenger entrances on LH side; one at front of front wheels another at rear of rear wheels without doors and passenger seats facing forward in 2x2 pattern.

2.0 REGULATION:

The general appearance, structure, seat layout etc., shall be in accordance with respective drawings. The bus body design should comply with the provisions of latest Central Motor Vehicle Rules, Andhra Pradesh Motor Vehicle Rules, Bus Body Code AIS:052 and any other statutory requirement that may come in to force.

2.0 MAIN DIMENSIONS: (ALL DIMENSIONS ARE IN MILLIMETERS)

SL NO	CHASSIS MODEL -> DESCIPRTION	TATA 244"WB
1	Wheelbase	6200
2	Rear overhang	3325 (53.6%)
3	Overall length	11705
4	Overall width (structure)	2590
5	Pillar centres (standard)	1130
6	Window sill(waist rail)height from top of the cross bearer	610
7	Waist rail height from Skirt level	1100
8	Cant rail height from waist level	1130
9	Interior saloon clear height (Minimum)	1920
10	Clear aperture of passenger service door (minimum when measured from the edge of door flap	650
11	Clear aperture of Driver door	650
12	Seating capacity	50+1 Driver

3.0 DRAWINGS: The list of drawings to be followed are shown at **ANNEXURE – I.**

4.0 MATERIAL: The fabrication of bus bodies shall be as per the specifications and recommended sources / brands of material mentioned in **ANNEXURE-II.**

5.0 CHASSIS POSITIONING:

5.1 All chassis received by the firm for fabrication of bus bodies should be kept safely in a covered area. The chassis should not be kept open to atmosphere without any protection to avoid damage to chassis and its units due to rain, dust and heat.

- 5.2 Before commencement of bus body fabrication all important units of chassis viz. Alternator, self-starter, radiator, tyres and batteries should be protected by providing suitable covering to prevent from damages that may occur due to welding, drilling, cutting, hammering, riveting, falling of metal scrap or dust during the course of fabrication. Driver seats, steering wheel, hand brake valves etc., shall also be protected from any damage or paint spray.
- 5.3 Chassis number on long members and identification plates provided by the chassis manufacturer shall be properly covered and protected before commencing the fabrication work.

6.0 PROTECTIVE TREATMENT:

- 6.1 All Mild Steel components used for fabrication shall be carefully de-greased, de-rusted with three in one solution by dipping and wiped with dry cloth to remove all dirt/oil etc., Then the material shall be applied immediately (without any time lag) with Zinc Phosphate epoxy primer "Rust-O-Cap" (part no.24570608320) of M/s. Asian Paints or "**60 BT PRIME GREY**" of M/s.Akzo-Nobel Coatings before assembly.
- 6.2 All Aluminium Components shall be carefully cleaned with thinner. Self Etch primer paint shall be used at joints of dissimilar metals. The interior and exterior panels should be cleaned with thinner and then self etching primer shall be applied.

7.0 BODY STRUCTURE:

7.1 Aluminium Structure:

All principal structural members should be in Aluminium extruded sections of Alloy designation 64430, 63400 and 65032, condition WP as per IS: 733– 1983. The structural joints shall be by riveting, bolting and combination of both. The rivets shall be of Aluminium alloy wire of IS: 740 – 1977. Alloy condition 64430 (HR-30) – OD.

Aluminium 5-bar chequered plate with 3.0/2.0 mm base thickness shall conform to alloy designation 65032 and condition WP of IS:737 of 1986.

All Aluminium sheets shall conform to alloy designation 19000, condition H2 of IS: 737 of 1986.

- 7.2 Chart no. CB18CTG132 and Drg.no. CB18AEG112 (sheet 1&2) containing the details of specifications of Aluminium extruded sections and sheets to be used, shall be followed.
- 7.3 Other Mild Steel / GI structural members:
Galvanized steel sheets should be as per grade 175 of IS: 277- 1985. Rolled sections should be as per IS - 2062 of 2006. The structural joints shall be by riveting, bolting, combination of both and MIG welding in case of MS/GI structural members. The welding should be for full length of joint. Welding slag to be removed and ground to smooth finish in order to avoid sharp edges.
- 7.4 All bolts used shall be of sizes reckoned in Metric system. The bolts shall be of high tensile hexagonal head bolts of fine thread, conforming to property clause 8.8 of IS: 1367 of 1979. The nuts shall be of approved anti-vibrate type such as Nyloc conforming to IS: 1364 of 1983. All bolts nuts and washers should be galvanized. Each bolt and nut shall be provided with a flat washer. A spring washer should accompany every tapped bolt. The approved brands of bolts are TVS / STL / HINDUSTAN FASTENERS/KFL/UNBRAKO/IMPERIAL FASTENERS brands only.

8.0 PARTICULARS OF IMPORTANT STRUCTURAL MEMBERS:

Sl.No	Description	Material
1	Cross bearers	Rolled steel channel ISMC 100x50x6 mm
2	Anti sag bar	Rolled steel channel ISMC 75x40x6
3	Floor longitudes	GI 'U' section 25x75x25x3 mm thick (5 rows)
4	Pillars and horizontal supports	Indal 2654 section, All pillars including wheel arch horizontal supports shall be reinforced with formed 'U' inserts of GI sheet 2.0 mm thick.
5	Roof sticks and roof longitudes	Indal 2651 section (5 rows)
6	Crib rail and Seat rail	Indal 1756 section
7	Cant rail	Indal 2800 section
8	Waist rail	Indal 2613 section
9	Waist rail stiffener	Indal 3402 section & 3.0 mm Aluminium 5-bar chequerred plate 100mm wide with minimum joints one on LH side and two on RH side with in Wheel base
10	Panel stiffener	Indal 3405 section
11	Skirt rail	MS Angle 40x40x3 mm
12	Water channel	
	a) On cant rail	a) Indal 6250 section
	b) Front & rear-end	b) Hindalco WC-695 section
13	Step edge beading	Indal 5700 section
14	Flat beading	Indal 5505 section
15	Decorative beading at	
	a) Exterior waist level front	a) Indal 2721 section
	b) Interior ceiling	b) Decorative beading with plastic filler and ends
16	Window sections	
	a. Window guide	a. Hindalco 6482 section
	b. Split section 1.	b. 'T' section
	c. Split section 2	c. 'F' section
	d. Sweep rubber section	d. Hindalco 2691 section
	e. Finger pull	e. Indal 1752 section
17	Wire casing	Indal 2735 section
18	Rub rail on body side	Indal 2676 section
19	Cleats & Brackets	
	a) Roof structure	a) Indal 1760 section
	b) Cant to roof stick and cant to pillar	b) 'C' bracket formed in GI sheet 2.5 mm
	c) Side Structure Roof grab rail brackets Gussets for Cross bearer to Pillar joint	c) 'C' bracket formed in GI sheet 2.5 mm at wheel arches and Indal 1760 cleats
20	Roof grab rail brackets	Indal 9638 of 30 mm wide powder coated in grey colour
21	Gussets for Cross bearer to Pillar joint	ISMC 100 X50

9.0 PRECAUTIONS:

- 9.1 Aluminium extrusions such as seat rail, crib rail, cant rail shall be joined with in wheelbase only.
- 9.2 "NEGATIVE TOLERANCES "are not allowed either for Aluminium Extruded sections or Aluminium sheets and GI sheets/tubes. However, tolerances within the limits of IS standards may be allowed subject to prior approval of Chief Mechanical Engineer (Chassis and Bodies) and recovery of difference of cost .
- 9.3 All holes in cleats and roof longitudes shall be PUNCHED to close tolerances. Under any circumstances drilling of holes is not allowed.
- 10.0 All welding shall be done with MIG welding process only. Under any circumstances, arc welding shall not be allowed. Welding of Stainless steel components shall be done with TIG welding process only with same grade Stainless Steel filler rod.
- 10.1 The following workmanship must be carefully followed during the fabrication.

- i. All castings must be truly formed and free from blow holes.
- ii. All bolts and rivets should be well fastened
- iii. Rigid water test shall be carried before fixing the interior ceiling using pressurized water spray system. The fabricator shall equip water leak test facility confirming to IS: 11865-1982 at the firm for conducting leak test in two stages i.e., before fixing the interior ceiling and before dispatch of vehicle.
- iv. All welded joints must be chipped and well ground to get a smooth surface and applied with Epoxy primer without any delay.
- v. Sharp corners shall be grounded and made smooth
- vi. Wherever pitch for rivets / bolts is not specified, it shall be 100 mm.
- vii. Bolt ends shall protrude at least 2 to 3 threads length above the nuts.
- viii. Roof stick, roof longitude, floor longitude and waist rail members shall butt properly at mating joints and shall not have gaps at the joints.
- ix. All tapping bolts such as grab rail, handles and assist rail bolts etc., shall be tightened using thread lock adhesive of approved makes.
- x. Roof stick, roof longitude, floor longitude and waist rail notching to be done on power press only.
- xi. All fixed glasses shall be provided with ceramic coating of suitable width on periphery.

11.0 CAB UNDERFRAME STRUCTURE:

- 11.1 The Tata 244" WB chassis shall be fabricated as per the drg.no.C4460UF18324. The cabin floor longitudinal members shall be connected to a 'Z' raiser in GI sheet 3.00 mm provided on 1st cross bearer to make up the height difference of cabin and saloon floor.
- 11.2 Difference of height of chassis long members at Rear Wheels with remaining portion is be equated duly providing MS plate of 6 mm thick on web mounting plates.
- 11.3 Suitable wheel arch boxes in rectangle shape fabricated in MS flat 40x6 mm and MS angles 40x40x6 mm shall be provided. The height of wheel arch box frame shall be 160 mm minimum from top surface of the tyre.
- 11.4 The dashboard frame shall be fabricated in MS angle 40x40x6 mm to the required profile and covered with GI sheet of 0.91mm thick. Flap door with suitable hinges and tower bolts shall be provided for easy access to fuse box, radiator and power steering reservoir.

12.0 BODY FRAME STRUCTURE:

- The bus body frame structure should be fabricated as per drawings C4460SL18322 and C4453SR18323.
- 12.1 The cant rail at the passenger entrance and driver door area shall be reinforced with GI sheet formed channel in 2.0 mm thick and the joint of cant rail should not be exactly on any pillar or within door bay.

- 12.2 A & B pillars on both sides shall be provided with GI 3 mm thick formed section similar to Indal 2654. First and second roof sticks connecting A& B pillars shall also be provided in GI formed section similar to Indal 2651 in 2 mm thick. All the structural members in this bay (Waist rail, Intermediate rail and roof longitudes) shall be in GI formed sections of 2 mm thick with dimensions of corresponding Aluminium Sections.
- 12.3 An opening of size 250-mm x 250 mm, fabricated in MS angles 40x40x6 mm. The opening is to be finished with flat beading (Indal 5505) and a flap with ball catcher shall be provided at fuel oil tank mouth.
- 12.4 MS tapping plates in **30x6** mm flat of 200 mm length shall be provided wherever tapping is to be done for fixing body components such as roof continuous beam, roof hand grab rail, window guard rail, assist rail, drivers' partition, windows etc.,
- 12.5 Cant rail on both sides full length shall be reinforced with MS angle 30x30x3 mm. This angle shall be riveted to pillars flanges at cant level and connected to the cant rail duly providing two GI plates of size 75x30 mm of 2 mm thick welded to the angle and riveted to cant rail in every bay.

13.0 CABIN AND BODY MOUNTING :

- 13.1 The OE Cabin floor and mounting arrangement shall be retained. The remaining portion of cabin floor connecting Ist-cross bearer and OE floor shall be fabricated as per drg. no. C4460UF18324
- 13.2 The OE anti-sag members shall be retained. If the chassis are not supplied with the anti-sag members a 3-piece anti sag channel in ISMC 75x40 shall be provided at front end of the chassis bottom frame connecting to the 'A' pillars on both sides.
- 12.3 Additional Out riggers in MS angles 50x50x6 mm shall be provided connecting 'B' pillars to the chassis long members with suitable fitment. The body should be mounted on the chassis web duly providing 6 mm (inverted pressed "L" type) MS plate as per the size shown in the respective drawings over the chassis long members. These "L" plates shall be bolted together at every cross bearer mounting to Long member web with M12x 50 H.T. bolts at least 4 nos. per plate. OE holes on the chassis long members shall only be picked up for mounting this plate. Wherever the OE holes are not available for bolting of web mounting plate, holes shall be drilled on the web 40 mm below the top level of long member with prior approval. Over these plates, cross bearers in ISMC 100x50 channels shall be provided as per the respective drawings. If the web mounting plate position at rear wheels coincide with rear spring bracket, the cross bearers shall be fastened with 16 mm dia. "U" bolts of approved make and with 150mm x 6 mm thick base plate welded to the bottom of cross bearer. Spacers made of Aluminium casting shall be placed between bottom flanges of chassis long member and "U" bolts. The "U" bolts are to be made out of EN-15/14B steel as per IS 5517-1978 (Tensile strength 80 kg/Sq.mm minimum). The "U" bolts should be galvanized and fitted with galvanized nyloc nuts as per drg.no. CB18UBG114. The length of bolt shall suit the depth of chassis long member and should not project more than 6 mm after tightening the nuts.
- 12.4 A tie bar in front of radiator in 3-piece in ISMC 75x40 connecting A-pillars on both sides and chassis long members shall be provided. This tie-bar to be mounted on MSL 50x50x6 mm angle 'L' brackets connected to the chassis long members.
- 12.5 The body mounting must be easily detachable from the chassis during major overhauls. Pillar gussets on four sides of the body shall be provided with 32 mm dia hole to facilitate lifting of the body during major overhauls.

14.0 CABIN AND SALOON FLOOR:

- 14.1 The cabin and saloon floor shall be in Aluminium 5-bar cheq.plate of 3.0 mm base thickness conforming to alloy designation 65032, Temper WP of IS: 737-1986. The cheq.plate should be riveted with MS rivets of 5mm dia. to the floor

longitudes at a pitch of 100 mm and in Zig-Zag manner at joints. The cabin area and wheel arch boxes shall be riveted at 75 mm pitch. The riveting on crib rail shall be done with 6 mm Aluminium alloy solid rivets of HR –30 and condition OD as per IS: 740-1977. Intermediate bolting with M8 bolts shall be done on cross bearers and wheel arch frames.

- 14.2 The wheel arches shall be made rectangle shape. The height of wheel arch box frame shall be 160 mm minimum from top surface of the tyre.
- 14.3 The number of cheq.plates used for cabin and saloon flooring should be least in order to keep the joints at minimum possible. The floor cheq.plate shall be joggled at crib level to get proper seating.
- 14.4 An inspection cover fitted to a frame in under frame with tapped bolts to be provided in saloon floor over fuel tank suction pipe of size 250x250 mm.
- 14.5 The floor longitudes should be in five rows excluding crib rails. They should be arranged in such a way that the seat legs are fixed on the floor longitudes. Dust proof rubber packing of EPDM quality, in 2 mm thick shall be provided at the joints and ends of chequered sheet to avoid entry of water / dust in to the saloon from the joints. The floor cheq.plate laying shall ensure dust proof. Floor longitudes shall be provided wherever necessary for floor plate joints and stanchions.
- 14.6 Trap door of 580x 520 mm size must be provided in cabin flooring above gearbox with proper sealing and M6 tapping bolts.
- 14.7 Four drain holes of 25-mm diameter and 75 mm length ERW pipe shall be provided in saloon flooring corners below seat frames for draining of water while washing.

15.0 BODY PANELING:

- 15.1 The exterior portion of body i.e., sides; front end, rear end, and roof exterior should be in Aluminium sheet 1.22 mm thick of alloy designation 19000 and condition H2 of IS: 737 of 1986.
- 15.2 Front radiator grill is to be provided in 3 mm thick FR grade FRP profile as per drawing.
- 15.3 Truss panel for body sides: Full height truss panel between waist to crib rail for entire length of body and at rear end including corners shall be provided in stainless steel sheet of 0.7 mm of 430 Grade and in scotch brite finish. These panels shall be riveted with 5 mm Aluminium alloy solid rivets to the structural members at waist rail together with 5 bar Aluminium chequered sheet and Indal 3402 stiffener at a pitch of 100 mm in zigzag manner. The riveting pitch on seat rail and crib rail shall be 75 mm. The riveting pitch on pillars shall be 100 mm.
- 15.4 **Roof structure reinforcement:** The roof structure above on each door opening i.e., passenger entrances and driver door between roof longitude and cant rail shall be reinforced with a truss panel of 0.91 mm thick GI sheet and shall cover three bays. The GI sheet in single piece has to be formed to the required contour of roof prior to the assembly and shall be riveted to the roof longitudes and cant rail lower flange and also to the MS angle 30x30x3 provided above cant rail between 'C' brackets with MS flat head rivets at a pitch of 100mm.
- 15.5 The roof exterior sheet for center portion should be in full length of body and laid longitudinally in one single piece of 1220 mm wide. The riveting should be done on the roof longitudes in ZIGZAG manner. The exterior sides (LH & RH) of roof sheets have to be provided in single piece as required. The riveting on cant rail, front and rear end roof sticks should be with flat beading Indal 5505. The overlap of roof exterior panels should be equal to full width of roof longitude section and should be riveted by 5.0-dia. Aluminium alloy solid rivets (HR-30) at a pitch of 75 mm in two rows ZIGZAG manner. While riveting roof side sheet on cant rail, an Aluminium sheet of 1.6 mm thick and 75 mm wide full length of cant rail shall be provided on the cant rail for pasting top fixed glasses. The sides of roof shall also

- be provided with water channel in Indal 6250 and shall be riveted along with flat beading Indal 5505.
- 15.6 In order to avoid water leakage overlapping portion of roof panels joints, overlapping portion of roof panels should be provided with white lead. The edges along the roof joints shall also be applied with white lead for filling up the gaps. Roof joints should be water leak proof. Approved make weather shield strip of 150 mm wide and 2 mm thick shall be laid longitudinally covering roof center joints from front end to rear end to avoid water leakage from roof.
 - 15.7 Exterior of roof sticks and longitudes shall be provided with expanded polyurethane sheet (Heat lan) of 6 mm thick.
 - 15.8 The interior roof up to cant should be in Aluminium sheet 0.91 mm thick of alloy designation 19000, condition H2 of IS: 737 – 1986.
 - 15.9 The interior vertical finishers for pillars, horizontal finishers for windows at cant level, waist level and finishers for intermediate rail shall be in 0.5 mm stainless steel of 430 grade and scotch brite finish. The finishers are to be pasted to structural members with PU sealants. There should not be any waviness in finishers and the sealant should not drip through the joints. All the horizontal finishers shall be in single piece per two bays and the overlap joints on pillars only. To avoid the expose of sharp edges and waviness of the SS sheet used, the inner edge of the finisher is to be bent inside and to be provided with suitable PVC 'U' beading.
 - 15.10 The overlap joint for roof interior ceiling panels should be on the roof sticks. The overlap of the roof panels should be equal to the full width of roof stick section and should be riveted by 4.76 mm dia. Aluminium alloy multi grip blind rivets at a pitch of 100 mm. Riveting should be done on roof longitudes and cant rail also.
 - 15.11 Interior ceiling panel joints on every roof stick, cant rail and on all sides of door openings shall be provided with decorative beading as per drawing with plastic filler and end covers.
 - 15.12 Aluminium sheet 1.22 mm formed to 'Z' section (size 25x45x25) shall be provided on waist rail which shall be riveted to waist rail duly overlapping the exterior body panel at a pitch of 100 mm. The ends of 'Z' section shall be bent vertically upwards to overlap the pillar web. Suitable 30x3mm thick balata packing shall be provided below the 'Z' section to match the height of rivet heads of waist rail. Ends and corners shall be applied with P.U.sealant to avoid seepage of water in to saloon.
 - 15.13 An Aluminium sheet formed 1.6mm thick 'Z' section (30x8x30) shall be riveted to intermediate rail with Aluminium flat head rivets of 5 mm to facilitate bonding of top fixed glass.
 - 15.14 Two rows of panel stiffeners in Indal 3405 should be provided at seat rail level and in between crib rail to skirt level.
 - 15.15 In order to avoid rattling of exterior panels 6 mm Heatlan felt packing shall be provided on panel stiffeners.
 - 15.16 The exterior body panels from waist to skirt should be without joints in 1.22 mm thick Aluminium Sheets of alloy designation 19000, condition H2 of IS: 737 of 1986. The vertical butt joint of panels should be on Structural members and to be pasted with approved make sealant of 'Metal to Metal' type and two sided VHB tape of 3M make on all sides i.e., vertical joint, on waist rail and on skirt rail. End portion of panels at wheel arches and skirt rail shall be folded inside by 20 mm and should be fixed with flat beading and Aluminium alloy head solid rivets of 5.0 mm dia. at a pitch of 100 mm.
 - 15.17 Rear end exterior from waist to skirt and between end pillars shall be provided with Aluminium sheet 1.22 mm sheet in single piece. This panel shall be bonded to the rear end structure with PU sealant of Metal to Metal type and VHB tape of 3M make. The rear end saloon glass frame shall be covered with 0.91mm finishers from outside and 0.5 mm stainless steel sheet from inside. Body

structural members and Aluminium sheet surfaces where the sealant has to be applied shall be cleaned thoroughly for oil/dirt etc., before applying sealant.

- 15.18 The body sides have to be provided with rub rail in Indal 2676 and insert as per CB16ERG122.
- 15.19 The front end exterior panels shall be provided with decorative beading Indal 2721 at waist rail. The beading shall be anodized and fixed with blind rivets. The rear end waist level shall be provided with Aluminium flat beading (Indal 5505) with blind rivets.
- 15.20 The exterior corner dooms both at front and rear on off side and near side from cant rail to waist and waist to skirt rail shall be provided in 0.91mm GI sheet overlaid with Aluminium sheet of 1.22mm thick and Indal 5505 beading on full length of pillars.
- 15.21 The area between exterior and interior panels of waist rail to crib rail in side structure, cant rail to cant rail in roof structure shall be provided with 45 mm thick thermocole insulation

16.0 FOOT BOARD:

The foot board structure at front and rear as shown in the drawing shall be in three steps built in MS. Angles 40x40x3 mm and overlaid with Aluminium 5-bar chequered sheet of 2.0 mm base thickness on sides and 3.0 mm base thickness on tread and riser portion. The footboard should be given a support under the lowest tread by providing a 'U' type bracket made of MS angles 40x40x6 mm. The arms of 'U' bracket should be 230 mm long and secured to pillars with M10x4 numbers bolts on each pillar. Step edge beading in Indal 5700 shall be provided along the edges. The bottom tread height from ground shall not be more than 400 mm. The tread depth should not be less than 300mm. Maximum step height allowed is 250 mm.

17.0 WHEEL ARCH FRAMES AND BOXES:

The rear wheel arch box frames should be fabricated in M S angles 40x40x6-mm and M S flats 40x6 mm in rectangle shape. The height of box frame shall be 160 mm above top surface of the tyre. The boxes should be designed to accommodate 10.00 x 20 size tyres. Aluminium 5-bar chequered plate of 3.0-mm base thickness in single piece to be used on top for covering wheel arch box frames. Step edge beading shall be provided at the riser and along the edges of wheel arch.

Mud guard shall be provided in 0.5 mm thick stainless steel sheet full round along wheel arch area with proper clamping and a clear gap of 100 mm from the edge of tyres.

18.0 DRIVER'S PARTITION:

The driver's partition shall be fabricated with stainless steel tube 30 x30x1.6 mm as per drg.no.CB18DRG119. It should be fixed behind driver seat and shall be supported on structural members duly reinforced in the floor as well as roof. The minimum distance from the Bonnet to partition wall shall be as per seat layout drawing. A timing board of size 450x300 mm shall be provided in Aluminium sheet 1.22mm duly painted white. The board should be provided in a sliding channel frame on 3 sides made of Indal 3620 section and fixed to the partition on saloon side.

19.0 DESTINATION BOXES AND BOARDS:

- 19.1 The front & rear destination boxes shall be on roof. The rear destination box shall be at bottom side of rear saloon glass as indicated in the structural drawings. The side destination box shall be in 1st 1130 mm bay on LH side at window top fixed glass area after front passenger entrance. The size of the destination boards should be 910x210mm.
- 19.2 One flap door in 0.7 mm stainless steel sheet of 430 grade in size 1180 mm x330 mm is to be riveted with piano hinge for full length at bottom and to be blind riveted

on intermediate rail in 1st 1130 mm window in front of middle entrance on LH side of body. Bracket in Indal 3620 is to be fitted on inner face of the door for holding the destination board of size 910 mm x210 mm. LED type light is to be provided for illumination. Two stainless steel locking latches and chain to be provided on both side for locking the door and to hold it at convenient angle to change board.

19.3 Six destination boards in GI sheet 0.91 mm have to be supplied along with the vehicle duly painted in white color. These destination board boxes in front and rear shall be provided in a WS-415 frame attached to the flap door with provision for keeping two boards. The destination boards should be visible clearly from outside.

19.4 The front, rear and side destination boards shall be illuminated by LED lights of 600-mm length of approved design and make with luminosity of 150 to 200 lux.

20.0 CONTINUOUS BEAM:

A longitudinal continuous beam in pressed top hat section of GI sheet of 2.0 mm thick similar to roof stick profile should be provided. This beam in inverted position shall connect all the roof sticks from front end to the rear as shown in the seat layout drawing. The joints should not be more than three with reinforcement using 30x25x2 mm thick, 50 mm long 'U' channel welded at joints from inside. There should not any mismatch at the joints, welded joints to be ground for even surface and ends should be tapered to a length of 150 mm. Reinforcement is to be provided in the beam with 30 x6mm in 200 mm length flats for fitment of stanchions

21.0 STANCHIONS:

Four stainless steel tube stanchions of 304 grade of 38 mm OD x 1.6mm thickness as per IS: 6913-1992 should be provided in between the saloon continuous beam and saloon floor as per seat layout plan. Suitable NYLON Sockets shall be provided at bottom ends of the stanchions and to be fitted on floor longitudinal members with through bolts and with tapped bolts on roof continuous beam of M6 size. The stanchions shall be fitted rigidly in sockets with M6 bolts and dome nuts.

22.0 CONTINUOUS ROOF HAND RAIL:

Two rows of continuous roof hand rail (grab rails) in stainless steel tube of 25 mm OD x 1.6 mm thick in 304 grade and 2B finish has to be provided as shown in seat layout drawing. These hand rails are to be provided with 18 nos. plastic moulded swiveling type hand holds with nylon ribbon arm slings in green/Yellow color, one per bay. Ends of these pipes shall be joined together duly inserting a pipe of 100mm long. The intermediate support brackets in Indal 9638 powder coated in grey color shall be used.

23.0 WINDOW GUARD RAIL:

Two rows of guard rails in stainless steel tube in 304 grade and 2B finish of 20mm OD x 1.6 mm thick as per IS: 6913-1992 has to be provided from outside on both sides of the vehicle at a height of 75 mm and 200 mm above waist level. The pipes shall be bolted to the pillars with M6 bolts and intermediate, end sockets. Tapping plates in GI flat 30x6 mm x 125-mm long shall be provided inside the pillar for fitment of guard rails.

24.0 CABIN FRONT WINDSCREEN, SALOON REAR GLASSES AND WINDOWS:

24.1 The cabin front-end shall be fitted with two curved windscreen glasses of size 1020x 1220 mm as per the sketch. The windshield glass frame assembly shall be

made in MSL 25x25x3 mm to match the profile of the curved glass. The windshield frame shall be provided between front cant rail and dash structure duly welded on all sides. The complete frame to be covered with 1.22 mm Aluminium sheet from outside and 0.5 MM stainless steel sheet from inside. The curved laminated glass shall be of 5.76 mm thick with minimum 0.76 mm PVB film, select float quality, safety clear WAVE FREE as per IS: 2553 – 1971 and to be fitted with 47.5 mm EPDM synthetic rubber extruded section. The approved brands for glasses are DURASAFE, DURATUF, ATULTEMP, REALSAFE, SEKURE, SEKURIT,GSC and . All corners of windshield glasses shall be provided with clamps in Aluminium sheet 1.6 mm in black powder coating

- 24.2 The saloon rear end glass shall be bonded to the MS angle 30x30x3 mm frame provided in the rear body structure with P.U. sealant. The single piece glass shall be of 1760 x 800 mm size in 5.0 mm thick, toughened safety clear glasses as per IS: 2553 – 1990 & IS: 2835 – 1987. The lettering work to be done on the glasses and at cant level as mentioned below:

“BREAK THE GLASSES IN EMERGENCY FOR EXIT “

In Telugu:

" అక్కవర సమయంలో ఏ అర్థమువైసను పగులగొట్టము"

- 24.3 The window frames in Hindalco 6482 extruded section shall be provided between waist rail and intermediate rail I-2654. For a standard bay of 1130 mm, the window frame size shall be 1125 x 673 mm. The window frame shall have two horizontal sliding glasses of 600x540 mm size with flock channel of EPDM rubber quality. The area between cant rail to intermediate rail shall be provided with a fixed glass of size 1127x450 mm. The glass shall be bonded to the 1.6 mm Aluminium sheet on cant rail and 1.6 mm Aluminium sheet 'Z' flange on the intermediate rail by applying Metal to Glass type PU sealant of approved make/ brands. The window glasses shall be of 5.0 mm thick toughened float quality, safety clear glasses as per IS: 2553 - 1990 & IS: 2835 – 1987. Window frames shall be black powder coated.
- 24.4 The edges of all sliding glasses shall be ground, chamfered and polished to smooth surface.
- 24.5 All window frames to be provided with corner cleats with flat rivets besides welding to the window corners. They should be fitted with M6x30 mm CSK head screws-2 nos. on each vertical side on pillars and -3nos. on intermediate rail. MS flat 30x6 mm tapping plates shall be provided on pillars and intermediate rail. Four drain slots of 50X3 mm shall be punched on side of window frame to drain out water collected in frame grooves.
- 24.6 All sliding shutters are to be provided with finger pulls in Indal 1752 section 100 mm long powder coated in black colour.
- 24.7 Vertical overlap of window frames on pillars shall be provided with a sealing rubber profile as shown in the drawing. The fixed glasses are to be secured intact.
- 24.8 Approved makes of EPDM rubber profiles Rubber extrusions &Moulding/ ASP/ALP.
- 24.9 Approved makes of P.U sealants are Total seal / Sikaflex / 3M India/ Bostik / Anabond and Henkel.

25.0 PASSENGER ENTRANCE, ASSIST RAILS AND DRIVER'S DOOR:

- 25.1 The passenger entrance cum exit on LHS side as shown in the drawings.
- 25.2 At rear entrance on both sides of step well, assist rails in stainless steel tube of 304 in 38 OD x 1.6 mm thick shall be fitted from roof stick to floor with approved make NYLON sockets and tapped bolted to the tapping plates provided in roof sticks at top and on cross bearers at bottom. Two horizontal support pipes and one diagonal support pipe in stainless steel tube of 304 grade in 32 OD x1.6 mm

thick shall be provided on both sides of step well. The pipes shall be fitted with approved make suitable NYLON sockets. If the bolts protruded outside of the sockets, they shall be provided with steel doom nuts.

25.3 DRIVER'S DOOR :

The driver's cabin door should full drop type on top and bottom sliding type duly extending up to floor level as per sketch no.CB18DRG119. The window frame shall be in Hindalco 6482 section as per the window design. The door shall have one heavy-duty door lock with outer handle, on1e locking latch from inside, striking plates and dovetail catches. The door shall be fitted with two forged hinges on 'A' pillar. Driver door frame shall be provided with one horizontal bar in stainless steel 20x1.6 pipe from inside for holding.

26.0 PASSENGER SEATS :

The seat layout plan and seating arrangement shall be as per the drawing.no.C4460SG18325.

26.1 SEAT FRAMES :

The legs of seat frames should be located on floor longitudes and seat rail only. Belting fabric 3 mm thick (one piece) shall be provided in between the floor and seat leg foot piece. The seat legs shall be fastened with M8X1.0 hexagonal head bolts using plain washers and Nyloc nuts. A provision for advertisement shall be made on seat back rests.

26.2 SEAT BOTTOM CUSHIONS:

Seat bottom cushions shall be provided in P.U. moulded foam conforming to grade "J" of IS: 8255 – 1976. The density of PU foam shall be between 45 to 50 kg / cu.m. and indentation hardness shall be between 15-17 Kgf at 25% deflection.

Sizes: Twin seater: 813 x 381 x 90/65 mm

The cushions to be mounted on 8.0 mm thick ply wood conforming to

Grade-MR, type-AA, as per IS: 303 – 1989. The upholstery shall be with expanded vinyl coated fabrics as per specifications of RDSO. The colour of rexine shall be in charcoal grey with prior approval of CME(C&B) only. The bottom plywood shall have 4 vent holes of 10 mm dia. per passenger seat. The bottom of plywood should be pasted with 1.0 mm thick ABS panel. The bottom should be fitted 25 mm ahead of seat frame level.

- 26.3 The PU moulded foam back cushion of 30mm base thickness as shown in the drawing and conforming to grade "E" of IS: 8255-1976 shall be mounted on 8.0 mm thick plywood of grade – MR, type-AA, of IS: 303-1989 and upholstered with same expanded vinyl coated fabric mentioned above. The back of plywood shall be pasted with 1.0 mm ABS sheet of matching shade and to be fitted with fibre grab handles on the back side of seat back.
- 26.4 All upholstery work shall be carried out with 3mm piping at all joints. A margin of 12 mm shall be provided for Rexene along the stitching lines and double stitching to be provided duly folding the Rexene edge by 6 mm. The tacking of Rexene to plywood to be by folding the Rexene by 12 mm with a pitch of 50mm in between nails.
- 26.5 The sewing thread makes to be of "MODI/COATS", variety no.38 as per IS: 1720-1978.

27.0 DRIVER SEAT:

- The OE knitted/web type driver seats supplied with chassis shall be retained. The driver seat frame mounting on cabin floor shall match the OE mounting position.
- 27.1 In case of non-supply of OE knitted driver seat with the chassis, approved make HDPE knitted driver seat of approved makes by corporation shall be fitted. The seat shall have fore and aft, up and down adjustment of 100mm with reclining back and to be fitted 350 mm away from steering wheel edge when the seat is fully forwarded.
- 27.2 The height of driver seat bottom shall be 450 mm when measured in fully lowered position.
- 27.3 There shall be a thigh clearance of 200 to 260mm between steering wheel edge and driver seating position
- 27.4 The driver seat shall be so located that the center line of driver seat shall be 705 mm away from the center line of body.
- 27.5 The driver seat shall be provided with "ELR" type safety belt of approved make. (AIS 05).
- 27.6 The driver seat frame mounting on cabin floor shall match the OE mounting position.

28.0 BATTERY BOX:

The battery box shall be provided on LHS side below floor level as per the drg.CB16BBG139 to accommodate two 12V batteries of size 521Lx292Wx248H mm with slider arrangement. The battery box is to be fabricated with MSL 40X40X6mm and MS Flat 40x6 and is to be paneled with 0.91 mm GI sheet on floor and three vertical sides. Interior of the battery box is to be overlaid with 0.5 mm stainless steel sheet of 430 grade. Wood packing shall be provided in the battery box on the sides of batteries to prevent vibrations while the vehicle is in operation. Four rows of single -length battery cables to be connected to the battery cut-off switch terminals to self starter and batteries. The terminals and cables should be firmly clipped in position.

29.0 ELECTRICAL WIRING AND OTHER FITMENTS:

- The earth return system of wiring should be used. All automotive cables used shall be of IS: 2465 – 1984 quality covered with PVC sleeve as per IS: 1951-1961. Wherever the cables have to pass through roof and side structures, PVC conduits of ½" dia shall be provided. There shall not be any loose or hanging cables, and if they pass through holes in panels or structural members other than roof and side structures, rubber grommets shall be provided in the holes of such panels and structural members and shall be securely clipped as near as practicable to such rubber grommets to avoid chaffing.
- 29.1 All wiring in saloon shall be carried through Aluminium extruded section wire casing Indal 2735 in two rows along the cant rail offside and near side in such a way that it shall be easily accessible at all points without the need to strip major

- paneling of body. The extruded section shall be so located and fitted as not to affect the appearance of body. Any wiring, which has to run along the chassis frame shall be securely, clipped to ensure that there shall be no chaffing with any of the moving parts. Further care shall be taken to route such wiring in such a way that it is not subjected to splashing of oil, water, mud etc.,
- 29.2 The battery main cable of size 398/0.40 mm shall be provided as required duly using good quality lugs with proper soldering, bolting and insulation etc., there shall be no joint in battery cables.
 - 29.3 The saloon and cabin are to be provided with 8 nos. of 390 X130 mm long LED light assemblies of approved makes as per layout drawing.
 - 29.4 All OE electrical fitments shall be retained and kept in working condition. Any extension of wiring harness should be done by providing male female connectors only. Tapping of power for saloon lighting etc., shall be taken from the OE female sockets provided by the chassis manufacturers. There should not be any tapping of power by slashing the main harness.
 - 29.5 The OE wiper machine, arm and blade supplied with the chassis shall be provided at cant level. Washer tank, if included in the system and supplied with chassis, is to be fitted on left side of front end structure at a convenient location. In case wiper assemblies are not supplied with the chassis 17 W Lucas TVS electrical wiper machine with blade of 610 mm length (min) shall be provided by the fabricator.
 - 29.6 One single tone Air horn of CEETEE model of Roots make shall be provided. The noise levels of these horns should be between 93 dB to 112dB.
 - 29.7 Piano switches as per IS: 9433 –1980, 230Vx5 amps shall be used. A 6-pole disc type fuse box with independent fuse designated for every electrical circuit shall be fitted on switch board provided at cant level. Maximum current capacity of a circuit shall not exceed 15 Amps. The current carrying capacity shall be 1.5 times the load current of the electrical circuit. The fuses used shall conform to IS-4063 / 1982. Switches and fuse box are to be fitted on hylam/decolam sheet of 3 mm thick and to be fitted on sunken tray located above the driver door with non metallic shielding to avoid short circuits.
 - 29.8 Cable ends shall be suitably crimped with lugs/soldered so as to with stand vehicle vibrations. The inter connections shall be made through couplers/ junction boxes / terminal blocks only. Weather proof connectors shall be used for connecting cables which are exposed to atmosphere to avoid water/moisture ingress during use.
 - 29.9 Four head light assemblies of 8” dia of AL type with suitable reinforcement for fitment on front end structure, are to be provided. They shall be fitted at a distance not more than 400 mm from the extreme outer edge body and not more than 1200 mm height from the ground.
 - 29.10 Two LED type indicators of 50 mm dia in amber colour are to be provided at front end below 1500 mm height on the outer edge of body in amber colour In addition to this, four more LED type direction indicator lamps (flat type) in amber color shall be provided on the lateral side of the body at wheels and below 1500 mm height from the ground.
 - 29.11 LED type height marker lamps in white color at front and in red at rear shall be provided. The marker lamps shall be above windshield glass at front and above cant level at rear on maximum possible outer edges.
 - 29.12 LED type tail lamps in 5” dia 3 nos on each side (one -red, one-white and one – amber) shall be provided. The mounting shall be below 1500 mm from ground and 400 mm from the outer edge. The red lights shall have individual circuits for parking and brake lights.
 - 29.13 Rear number plates shall be provided with LED type light assembly of 300 mm length
 - 29.14 Electrical side flashers of LED type in amber color shall be provided at cant level on all four corners.

- 29.15 OE battery cut-off switch supplied with chassis shall be provided with separate fuse control. In case of non supply of battery cut-off switch along with the chassis, IGSA-552 or part no. LP-134/3 of Lucas India Services Ltd., make shall be fitted in driver's cabin with a label "Battery Cut -off switch". The battery cut-off switch to be located 300mm above the cabin floor on 3.00 mm GI plate provided in side structure.
- 29.16 One 24V, 3-pin plug socket has to be provided on the dashboard in driver's cabin for connecting inspection lamp/ TIMS.
- 29.17 Six speakers of approved make shall be provided (one in cabin and five in saloon) along with approved make Amplifier. The speakers shall be fitted to roof duly mounting on FRP speaker box of approved design. Amplifier fitted in FRP box with lid and locking arrangement is to fitted in driver cabin at suitable location.
- 29.18 Conductor's buzzer with bell switches 4 nos. to be provided.
- 29.19 One reverse gear horn/alarm (4 tone) shall be provided with noise level not more than 100 dB if not supplied with the chassis.
- 29.20 All LED type lights shall comply with the specifications furnished at **Annexure-III**
- 29.21 In the driver cabin Instrument panel with all gauges, OE switches & indicators with labels shall be provided at 45-degree angle and shall be in the reach of driver from his seat. The frame shall be fabricated in MS angle 25x25x3 mm covered with 1.22 mm thick GI. sheet.
- 29.22 Power for connecting Wiper, Indicators, shall be drawn from the sockets provided duly providing male / female sockets.
- 29.23 Never connect the circuits with twists & knots. Never tap power by slashing the main harness.

30.0 BODY PAINTING AND COLOR SCHEME:

- 30.1 Body to be painted on the exterior and interior with synthetic air-drying coat type enamel paints. The body under frame and chassis shall be painted with anti corrosive rubberized paint. The exterior painting process shall consist of carefully cleaning and etching followed by self etch primer coat, an under coat, finish coat and glaze coat.
- 30.2 Approved paint brands are: 'Autostar' of AKZONOBEL Ltd., or 'Aspa' of Asian Paints or Nova plus of Kansai Nerolac.
- 30.3 Color Scheme - Color scheme should be as per sketch given:

a) Exterior portion

Shade	Shade reference
Crystal white	ICI -169037
Satin black	ICI-169003
St. Germaine Red	ICI-169222

b) Interior portion

i. Interior roof, cant to crib level	Franchise white	ICI-169012
ii. Seat frames	SE black	ICI-169002
iii. Destination boards, inside portion of boxes	White	ICI-169001
iv. Number plates	Golden Yellow back ground and black color letters/numbers	size 65Hx10TH and 10 mm spacing

The color scheme may be modified or changed at the time of execution of bus body fabrication as per the orders of Chief Mechanical Engineer (C&B).

- 30.4 APSRTC monogram shall be provided on both sides of body at center portion as per SKETCH1516 in image transfer stickers.

31.0 MISCELLANEOUS FITTINGS TO BE PROVIDED:

- 31.1 Two Fiber handles of 100 mm size are to be provided at waist level of cabin front end. Two footsteps on the bumper shall be provided for cleaning of front windshield. Footsteps should not protrude outside the bumper.
- 31.2 Two OE fully adjustable rear view mirrors of convex type supplied with chassis shall be fitted with brackets. One convex mirror to be fitted inside driver cabin. The location of rear view mirrors shall be so located to have at least 2500 mm wide vision from the body line of vehicle when viewed from driver seat.
- 31.3 The registration number plates shall be exhibited in black alphabets/numerals with golden yellow back ground. The front registration number plate in Aluminium sheet 1.6 mm to be provided on the front bumper with Indal 5505 beading around registration number plate. The size of the number plate shall be 450x250 mm. The rear registration number plate shall be on rear bumper. The size of the Alphabets/ numerals shall be 65H x 10 TH and with 10mm space in between the Alphabets/ numerals. There shall be a hyphen of 10x10mm separating the code and 4-digit number.
- 31.4 The registration number shall also be painted and exhibited in interior, facing the passenger seats. The registration number shall also be painted on the right and left side of the body as per the CMV Rules, 1989.
- 31.5 One revenue permit board and one fitness certificate board of size 300x225 mm in Indal 3620 frame, glass and back plate in Aluminium sheet 1.22 mm complete shall be provided. The frames are to be black powder coated.
- 31.6 Two fire extinguisher of approved make and dry chemical type 2.0 kg capacity conforming to IS: 2171 of 1985 suitable for 'B & C' class of fires shall be provided with suitable MS clamping arrangement.
- 31.7 Rubber mud splashguards of size 650x456 mm for rear and front wheels to be provided.
- 31.8 First aid box of Stainless steel and in size 310x220x128 mm with leather straps and locking arrangement shall be provided in driver's cabin. First aid medicine kit containing the items mentioned under Rule 138(d)(4) of the latest M.V.Rules shall be provided in the box.
- a. Antiseptic cream of 5.0% centrimide I.P
In non-greasy base 5 mg ...2 pcs.
 - Sterile Surgical gauge dressing ...1 pack of 4 pcs.
 - Wash proof plaster ... 5 pcs.
 - Sterile elastic plaster – size 6cmx30 cm ... 1 pc.
 - Gauge rollede – size 7.5 cm x 2.5 mtr. ... 3 pcs.
 - Elastic bandage for wounds and burns
Size – 8 cm x 1.5 mtr. ...1 pc.
- 31.9 One pair of towing hooks with 36 mm eye dia. in MS flat 75x12 shall be provided at the rear end, to be attached to chassis long member with 4nos.M12 bolts.
- 31.20 All lettering work in vinyl stickers shall be done as per the guidelines.
- 31.21 The rear bumper should be in GI sheet 3.0 mm thick-formed channel section of size 50x175x50 mm in single piece with brackets in MSL 40x40x6mm and to be fitted to the chassis long members. The ends of the bumper to be curved. The right side portions of bumper shall be made sunken to accommodate a registration number plate and number plate light.
- 31.22 Front bumper shall be fabricated in GI. sheet 3 mm of size 40x300x40 mm to suite the body width. The mounting shall be attached to chassis long members with MS angle 50x50x6 mm 400 mm long.
- 31.23 Two sunken footsteps of size 150x150mm shall be provided below the driver door one at 700 mm height from the ground and another at 950 mm.
- 31.24 The entrance and driver's door shall be provided with water drain canopies at cant level in Aluminium sheet 1.22mm.
- 31.25 Pure rubber matting of 3.0mm thick shall be provided for foot control pedal in driver's cabin.

- 31.26 A footstool for driver to be provided in Aluminium 5-bar cheq. Sheet 3.00 mm and Indal 2651 as legs.
- 31.27 Tapping of compressed air for windscreen wiper and air horn should be from port no.24 of system protection valve or auxiliary tank with proper unions, 'T' joints. Metallic pipeline of 5.0-mm dia. with copper coating on inner wall shall be used for tapping. The pipeline shall be firmly clamped in position.
- 31.28 One roller type sun visor of 24" size to be provided in driver cabin
- 31.29 Driver & engine bonnet to be separated from passengers by providing one row of stainless steel pipe of 304 grade 32 OD x 1.6 mm thick vertical supports and NYLON Steel sockets.
- 31.30 All unutilized chassis components to be returned to Corporation at the time of delivery of bus.
- 31.31 The seats earmarked for ladies, PHC persons, senior citizens are to be very clearly exhibited on seat back rests.
- 31.32 Retro-Reflective Conspicuity Marking tapes of 50 mm wide conforming to AIS :90 of approved make shall be bonded to the body sides as per the sketch provided. The cumulative length of tapes provided shall not be less than 80% of length of that side. These tapes shall be white in color at front, yellow on sides and in red at rear of the body.
- 31.33 Driver's cabin shall be suitably ventilated. One Aluminium disc ventilator shall be provided below dash structure.
- 31.34 One stainless steel assist rail of 32 mm dia x 1.6 OD up to a height of 600 mm from floor shall be provided on rear side pillar of driver door from inside.
- 31.35 A slogan in Telugu to be exhibited as follows on the back side of Front dest.box flap door.

“ఈ బస్సు మనందరిది !

దీనిని పరిశుభ్రంగా వుంచుదాం !! ”

PROVISIONAL:
 CONFIRMATION TO BE OBTAINED BEFORE
 COMMENCEMENT OF FABRICATION

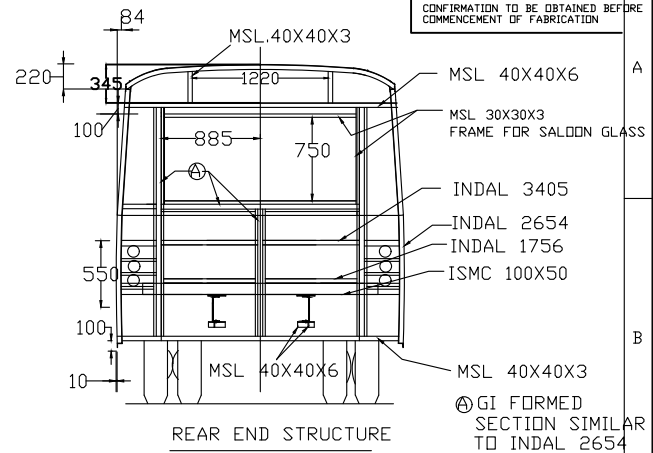
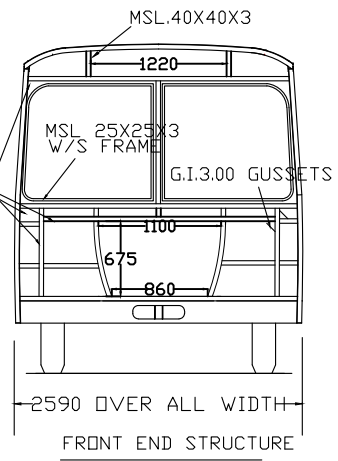
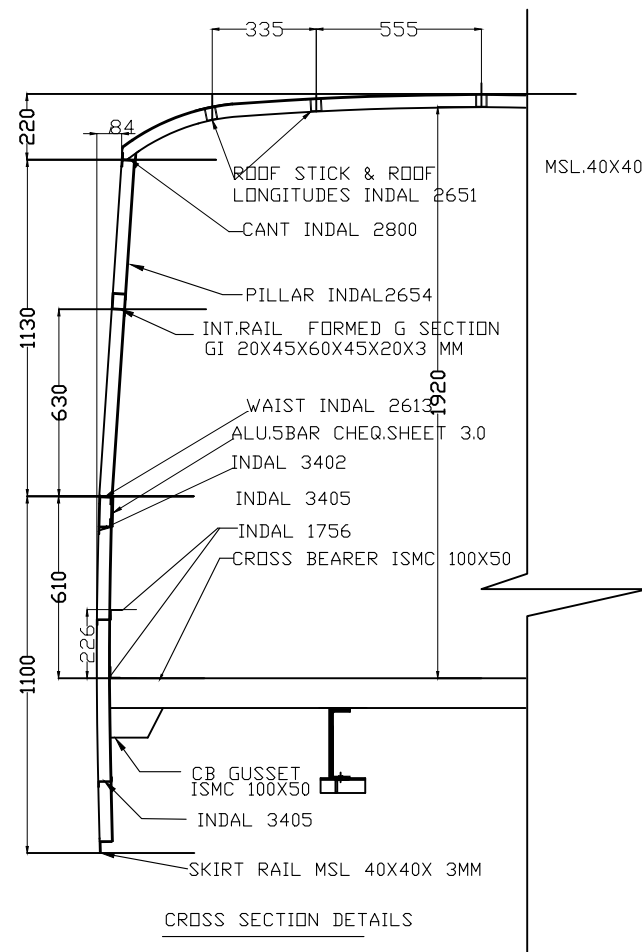

ANDHRA PRAESH STATE ROAD TRANSPORT CORPORATION				
NOTE: UNLESS OTHERWISE SPECIFIED ALL DIMENSIONS ARE IN MILLIMETERS DO NOT SCALE DRAWING, DEBUR AND BREAK ALL SHARP EDGES		TITLE BODY CROSS SECTION DETAILS		
DRAWN	CHECKED	APPROVED	SUB TITLE	CROSS SECTION DETAILS
DESGN. AE(M)	AME(C&B)	Dy.CME(C&B)	TYPE OF BODY	CITY-ORDINARY
SIGN.			CHASSIS & RDH	TATA 244' WB & 60 %
		DATE	SEATING	50 + 1 DRIVER
		MATERIAL: AS PER SPEC	DWG NO.	C4460CS18326
REVISION	DATE			A4

LEFT SIDE STRUCTURE FOR CITY ORDINARY BUS ON 244" WB TATA SLF CHASSIS

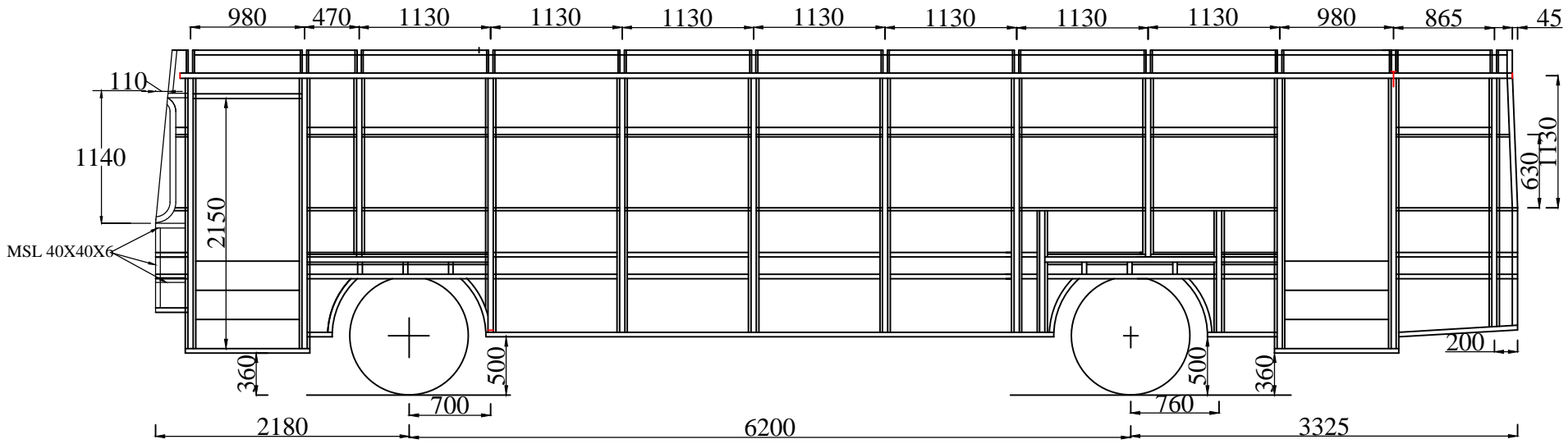

PROVISIONAL:
 CONFIRMATION TO BE OBTAINED BEFORE
 COMMENCEMENT OF FABRICATION

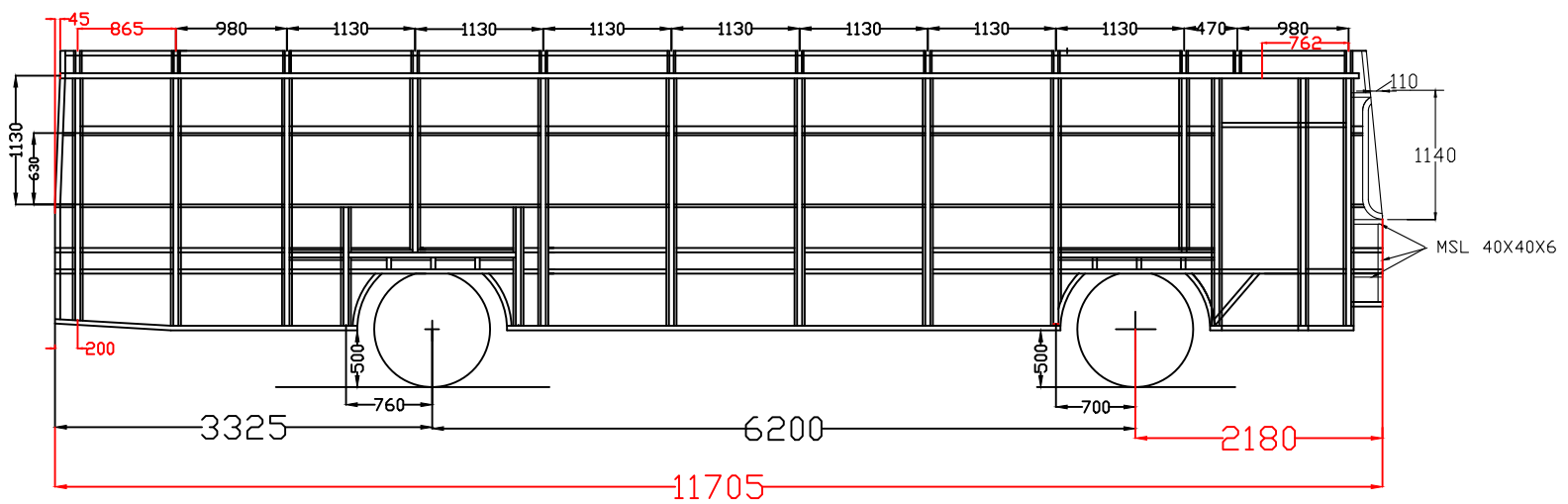

ANDHRA PRAESH STATE ROAD TRANSPORT CORPORATION

NOTE:
 UNLESS OTHERWISE SPECIFIED
 ALL DIMENSIONS ARE IN MILLIMETERS
 DO NOT SCALE DRAWING,
 DEBUR AND BREAK ALL SHARP EDGES

TITLE BODY CROSS SECTION DETAILS

DRAWN	CHECKED	APPROVED	SUB TITLE	RHS STRUCTURE
DESGN. AE(M)	AME(C&B)	Dy.CME(C&B)	TYPE OF BODY	CITY-ORDINARY
SIGN.			CHASSIS & RDH	TATA 244" WB & 60 %
		DATE	SEATING	50 + 1 DRIVER
		MATERIAL: AS PER SPEC	DWG NO.	C4460SR18323
REVISION	DATE			A4

4 WEIGHT: 5 SCALE: 6 SHEET 1 OF 1

PROVISIONAL:
 CONFIRMATION TO BE OBTAINED BEFORE
 COMMENCEMENT OF FABRICATION

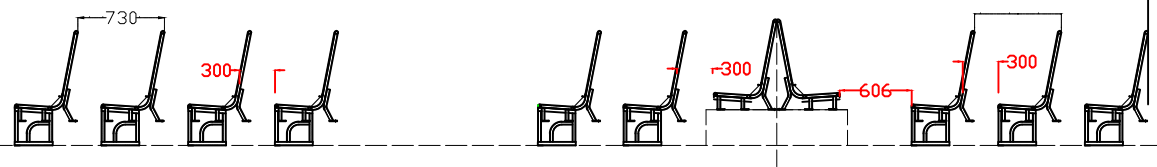
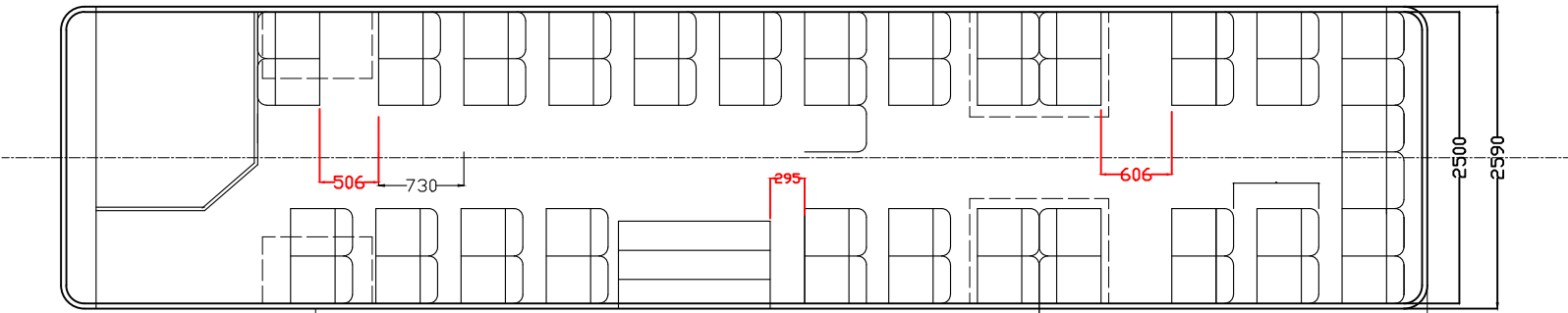

LAYOUT: 2 SEATER : 2 X 22 = 44
 6 SEATER : 6 X 01 = 06

ANDHRA PRAESH STATE ROAD TRANSPORT CORPORATION

NOTE:
 UNLESS OTHERWISE SPECIFIED
 ALL DIMENSIONS ARE IN MILLIMETERS
 DO NOT SCALE DRAWING.
 DEBUR AND BREAK ALL SHARP EDGES

TITLE BODY CROSS SECTION DETAILS

DRAWN	CHECKED	APPROVED	SUB TITLE	SEAT LAYOUT
DESGN. AE(M)	AME(C&B)	Dy.CME(C&B)	TYPE OF BODY	CITY-ORDINARY
SIGN.			CHASSIS & ROH	TATA 244" WB & 60 %
	DATE		SEATING	50 + 1 DRIVER
REVISION	DATE	MATERIAL: AS PER SPEC	DWG NO.	C4460SG18325
				A4